







BANDSAW BLADE DIMENSIONS FOR PEDRAZZOLI SAWS

	LENGTH	WIDTH	THICKNESS
SN300 BANDSAW	111.2"	1.062"	.035"
SN420 BANDSAW	124"	1.062"	.035"

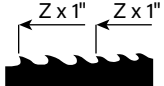
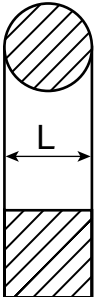
BANDSAW BLADE SELECTION

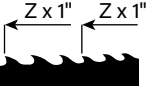
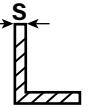
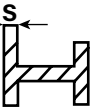
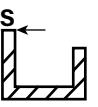
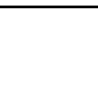
	S inches				L inches			
	< .060	14	-----		< 1½	8	6/10	
	< .158 - .316	10	10/14		< 1½ - 3⅞	6	5/8	
	> .083 - .158	8	8/12		< 2⅞ - 3½	4	4/6	
	> .158 - .316	6	6/10		> 4	3	3/4	
	> .141 - .282	6	5/8	Reduced speed for stainless steel and large sections				Emulsion
	> .282	4	4/6					Emulsion

7+10%

TYPICAL BLADE MATERIALS

BIMETAL	- Interrupted cuts; structural steel; tubes.
COBALT M42	- Automatic saws and machines for production, hard metal, stainless steel.
HARD METAL H.M.	- Hardened special bronze, AMPCO, material COBALT M43 has difficulty cutting.
ONEMETAL/SL	- General and occasional use; with low tool cost.
ONEMETAL/SR	- Efficient higher cutting with production.
COBALT/51	- Hard material with automatic machine cycle.